

Contiguity Theory and Crystallization: *wh*-phrases and concord adverbs in Japanese

Akitaka Yamada

Georgetown University

ABSTRACT. The common machinery for deriving movement in Minimalist studies of syntax dwells on the diacritic feature, aka, the EPP feature, which is no more than an artificial stipulation that says that things move because they have to without explaining why this necessity exists. If we build a theory of syntax without such an EPP feature, interface-conditions are good candidates that are likely to be responsible for the motivation for movements. Contiguity Theory pushes this idea, arguing that phonological conditions play more roles in syntax than we traditionally assume and apparent syntactic differences between languages are always the consequence of more fundamental phonological and morphological parameters. By examining three puzzles concerning Japanese conditional clauses and their interaction with *wh*-elements and concord adverbs, this paper investigates this theoretical possibility and proposes that a requirement on the prosodic tree — the contiguity requirement (Richards 2010, 2016, 2018; Branan 2018) — should obey another condition, which I call CRYSTALLIZATION. Emphasis is put on the fact that the existence of such a condition is justified on an acoustic ground, *i.e.*, as a consequence of an attempt to create a well-formed pitch-boosting distribution. In other words, constraints on movement are argued to be empirically detectable and justifiable by easily accessible E-language properties, exhibiting a sharp contrast with attempts that blindly exploit features which cannot be observed other than their ability to trigger overt movement.*

Keywords: contiguity theory, concord adverbs, scrambling, prosodic requirements, crystallization

1. Introduction

Recent studies have reached the conclusion that a number of grammatical phenomena and effects that have previously been argued to be syntactic in nature are indeed appropriately explained on phonological grounds (Richards 2010, 2016, 2018; Branan 2018). An illustrative example is the explanation/prediction of overt/covert movements. When we discuss whether a given language is equipped with an overt *wh*-movement, it has been a

* This project stemmed from my final project of a course at the 2017 LSA Linguistic Summer Institute at University of Kentucky. I would like to express my deepest gratitude to Norvin Richards for his exciting lectures on prosody and syntax and insightful comments on my work. I am also grateful to the other members of the 2017 LSA Summer Institute workshop “phonological externalization of morphosyntactic structure: universals and variables,” Hisao Tokizaki, Yoshihito Dobashi, Kuniya Nasukawa and Hitomi Onuma, who gave me many suggestions and useful feedback. All remaining errors are, of course, my own.

common practice to speak of the strength of the feature (‘strong’ vs. ‘weak’) and/or of the presence/absence of an edge/EPP-feature. Researchers have, however, started being critical about our optimistic exploitation of such assumptions. Two such recent comments are, for example, cited below:

But this theoretical device merely rephrases the problem. It essentially is equivalent to stating that “for some mysterious reason, which reminds us of some properties of ‘viruses’ in medicine, overt movement must take place before Spell-Out.” (Kitagawa 2017)

[T]he literature is quite forthright about being unable to predict which heads will have this property (Richards 2016).

Rather than appealing to such a diacritic feature — whose existence is by no means detectable other than being stipulated — we may attribute the motivation for movement to other observable feature of natural language. Contiguity Theory, developed by Richards (2010, 2016, 2018) and Branan (2018), claims that we can and should analyze some otherwise mysterious grammatical facts as a consequence of principles about metrical and prosodic structures, providing a unified explanation not only to the issue of overt/covert *wh*-movements but also to affix supports, head-movements and wide range of intervention effects.

The main purpose of this paper is to develop this phonology-oriented approach to syntax by examining three puzzles about Japanese conditional clauses and their interaction with the *wh*-element. In Section 2, the three puzzles are introduced; namely, (i) the adjunct puzzle, (ii) the adverb puzzle and (iii) the scrambling puzzle. It will be shown that the intervention-based pure syntactic approach is not adequate to explain the puzzles. As an alternative, I will present a phonology-based explanation. In Section 3, the outline of Contiguity Theory is introduced and, based on this, in Section 4, I will argue that acceptable sentences and unacceptable sentences are predicted based on the well-formedness of their prosodic structures. In so doing, I will modify some theoretical assumptions of the previous studies by proposing a new condition, which I call CRYSTALLIZATION. In Section 5, I will justify this novel claim by showing that this condition is a reflex of an acoustically reasonable constraint on post-focal reductions. I will conclude the paper in Section 6.

2. Japanese conditional clauses and three puzzles

2.1 Japanese conditional clauses

Before looking at the very puzzles, let us begin this section with two important facts about Japanese conditional clauses. Japanese conditional clauses are different from those of English in that (i) they have multiple complementizers that head conditional clauses and (ii) they are accompanied with concord adverbs or *koo-no hukusi* ‘adverbs of concord.’ First, in Japanese, there are several conditional markers available to form the conditional clause (*e.g.*, *-(re)ba*, *-tara*, and *-nara*). For example, in the three examples in (1), different complementizers are used in the antecedent clause. Admittedly, they differ in nuance and syntax (see for example, Mihara 2012; Yamada 2014) but the subsequent discussion does not hinge upon the choice of the complementizers.

(1) Complementizers for conditional clauses

- a. [*Satoo-o* *ire-te-reba*] *oisiku-nat-ta-kamosirenai.*
 sugar-ACC put-PRF-if delicious-become-PST-may
 ‘If we had put sugar in it, it may have become sweeter.’
- b. [*Satoo-o* *ire-te-tara*] *oisiku-nat-ta-kamosirenai.*
 sugar-ACC put-PRF-if *delicious*-become-PST-may
 ‘If we had put sugar in it, it may have become sweeter.’
- c. [*Satoo-o* *ire-te-ta-nara*] *oisiku-nat-ta-kamosirenai.*
 sugar-ACC put-PRF-PST-if *delicious*-become-PST-may
 ‘If we had put sugar in it, it may have become sweeter.’

Second and more importantly, Japanese contains a set of adverbs associated with the conditional clause, such as *mosi*, *mosi-mo*, *kari-ni*, and *man-ga-iti*, which have been called CONCORD ADVERBS in traditional Japanese linguistics (Yamada 1936; Tokieda 1950; Watanabe 1971; Kudo 1982, 2000; Sawada 1993; Morimoto 1994, 2011; Sugimura 2012). Unfortunately, there is no good English adverb for the translation of these words, but the following analogy may be useful to clarify their status. In order to encode the weak epistemic modal meaning, English can use both the epistemic adverb *maybe* (which appears as an adjunct) and the epistemic auxiliary *may* (which appears in a head position). This is a kind of head-adjunct relation. Japanese also exhibits such a head-adjunct relation in the domain of epistemic modals. But, in addition, this language is also equipped with such a head-adverb correspondence in the conditional domain. The sentences in (2) are minimally different from

(1) in that the antecedent contains a concord adverb *mosi*. If English had a word ‘*ifbe*’ — just as *maybe* is the corresponding adverb for *may* — this would be the closest translation.

(2) Complementizers for conditional clauses

- a. [*Mosi satoo-o ire-te-reba*] *oisiku-nat-ta-kamosirenai*.
 CON.ADV sugar-ACC put-PRF-if delicious-become-PST-may
 ‘If we had put sugar in it, it may have become sweeter.’
- b. [*Mosi satoo-o ire-te-tara*] *oisiku-nat-ta-kamosirenai*.
 CON.ADV sugar-ACC put-PRF-if *delicious*-become-PST-may
 ‘If we had put sugar in it, it may have become sweeter.’
- c. [*Mosi satoo-o ire-te-ta-nara*] *oisiku-nat-ta-kamosirenai*.
 CON.ADV sugar-ACC put-PRF-PST-if *delicious*-become-PST-may
 ‘If we had put sugar in it, it may have become sweeter.’

The semantic contribution of this word is to intensify the hypotheticality of the proposition depicted in the conditional clause. For example, due to the presence of *mosi*, the hypotheticality of the antecedent clauses in (2)a is considered stronger than that of (1)a, which resembles the fact that multiple instances of weak epistemic modal elements intensify the hypotheticality; if we compare (3) with (4), we feel that the hypotheticality expressed by (3) is stronger than (4).

(3) *Maybe*, he *may* come.

(4) He *may* come.

Three observations deserve our attention. First, this item is an adverb and thus it is an optional element; one can make a conditional clause with or without its existence, as illustrated in (1) and (2). As shown in (5), the fact that *mosi* alone cannot form a conditional clause also suggests that this is not a head of the conditional clause but an adverb.

(5) *Mosi* conditional without *-ba* (*-tara/-nara*)

- *[*Mosi satoo-o ire-te*], *oisiku nat-ta-kanaa?*
 CON.ADV sugar-ACC put-PRF delicious become-PST-Q
 ‘If we had put sugar in it, would it have become delicious? (intended)’

This is a difference from English *maybe*. *Maybe* does not presuppose the existence of *may* in the corresponding head position. For example, in addition to (3) and (4), (6) is also an acceptable sentence in English. But *mosi* requires there to be a corresponding head and (5) is syntactically illicit.

(6) *Maybe*, he comes.

Second, this adverb is related only to the conditional clause, not to any other kind of adverbial clause such as temporal clauses or reason clauses, as in (7).

(7) *Mosi* in temporal and reason clauses

*[**Mosi** *satoo* *ire-te-ta-{toki/kara}*] *oisiku-nat-ta-kamosirenai*.
 CON.ADV sugar put-PRF-PST-when/because delicious-become-PST-may
 ‘When/because we had put sugar in it, it may have become sweeter (intended).’

Third, contrary to its historical origin, this adverb is no longer observed in the matrix clause, as in (8).¹

(8) *Mosi* in matrix clauses

{*Mosikasite*/***Mosi**} *inai* *aida-ni* *uwaki-o* *s-iterir-u-kamosirenai*.
 {perhaps/CON.ADV} absent time-during seven-year-itch-ACC do-PRG-PRS-may
 ‘Perhaps, she has had an affair with someone while I was absent.’

¹ Diachronically speaking, this adverb is derived from an epistemic modal adverb. The example below is taken from a text written in the 10th century, which includes *mosi* in a non-conditional environment.

(i) *Mosi* as an epistemic modal particle (Kokinwakasyu Vol.18, 994)
 [*mosi naki ma-ni kotogokoro-mo-ya ar-u*]-*to utagap-ite*,
 maybe absent time-during seven-year itch-SFP-SFP be-PRS-that doubt-and
 ‘he doubted “maybe, there is a seven-year itch in her while I am absent” and ...’

One can find this type of epistemic *mosi* especially in the literature written early in the 20th century, but nowadays, it has become obsolete and its epistemic modal origin is only visible in some fossilized expressions as in (ii).

(ii) Expressions developed out of *mosi*

a. Epistemic modal adverb ‘maybe, perhaps’:

mosi-ya, (*mosi-ka*), *mosi-ka-s-ite*, *mosi-ka-sur-u-to*, *mosi-ka-s-itara*, ...

b. Disjunction ‘or’:

(*mosi-wa*), *mosi-ku-wa*, ...

2.2 Three puzzles

Japanese conditional clauses and concord adverbs give us three challenging puzzles in interaction with *wh*-elements. Here, we will examine these three puzzles.

2.2.1 Puzzle 1: adjunct puzzle

The first puzzle is what I call the ADJUNCT PUZZLE, which is about the well-known typological difference concerning the *wh*-phrase that originates in the adjunct clause. As is known, English cannot extract the *wh*-phrase out of the adjunct clause (= (9)). The corresponding Japanese data is given in (10), which, unlike English example, is by all means acceptable. Why does such a typological difference emerge and how can we predict the well-formedness in (10)?

(9) English

**What_i* would the soup become more delicious [_{CP} if I had put ~~*what_i*~~ in it]?

(10) Japanese

[_{CP} [_{CP} *Nani-o ire-te-tara*] *oisik-u nat-ta ka-naa*]?
what-ACC put-PRF-if delicious-ADV become-PST Q-SFP

‘*What_i* would (it) have become delicious [_{CP} if I had put ~~*what_i*~~ in it]? (lit.)’

(*cf.*, what would have made it delicious if I had put it in?)

2.2.2 Puzzle 2: adverb puzzle

The acceptable sentence in (10), however, becomes unacceptable, if there is a concord adverb within the conditional clause. Typically, adverbial phrases are transparent in *wh*-extraction. For example, the sentence in (11)b is no less acceptable than the sentence in (11)a and (11)c is no more grammatical than (11)d.

(11) a. Who did you go to Spain with?

b. Who did you go to Spain with *last summer*?

c. **What_i* would the soup become more delicious [_{CP} if I had put ~~*what_i*~~ in it]?

d. **What_i* would the soup become more delicious [_{CP} if I had put ~~*what_i*~~ in it *at that time*]?

Likewise, temporal adverbs in Japanese do not make the sentence any less or any more licit than the corresponding sentence without an adverbial phrase. For example, the sentence in (12)b is just as good as the sentence in (12)a.

(12) Temporal adverbial phrases

- a. [_{CP} [_{CP} *Nani-o ire-te-tara*] *oisik-u nat-ta ka-naa*]?
what-ACC put-PRF-if delicious-ADV become-PST Q-SFP
 ‘What_i would (it) have become delicious [_{CP} if I had put ~~what_i~~ in it]? (lit.)’
- b. [_{CP} [_{CP} *Anotoki nani-o ire-te-tara*] *oisik-u nat-ta ka-naa*]?
that time what-ACC put-PRF-if delicious-ADV become-PST Q-SFP
 ‘What_i would (it) have become delicious [_{CP} if I had put ~~what_i~~ in it at that time]? (lit.)’

However, if a concord adverb is used, the acceptability of the sentence is degraded. For example, observe the following pair in (13); *n.b.*, the sentence in (13)a is the same as (12)a. In (13)b, an adverb *mosi* is put in place of *ano toki* ‘that time’ and this replacement makes the sentence unacceptable.

(13) Concord adverbs

- a. [_{CP} [_{CP} *Nani-o ire-te-tara*] *oisik-u nat-ta ka-naa*]?
what-ACC put-PRF-if delicious-ADV become-PST Q-SFP
 ‘What_i would (it) have become delicious [_{CP} if I had put ~~what_i~~ in it]? (lit.)’
- b. * [_{CP} [_{CP} *Mosi nani-o ire-te-tara*] *oisik-u nat-ta ka-naa*]?
CON.ADV what-ACC put-PRF-if delicious-ADV become-PST Q-SFP
 ‘What_i would (it) have become delicious [_{CP} if I had put ~~what_i~~ in it at that time]? (lit.)’

This is the second puzzle (the ADVERB PUZZLE). Why do concord adverbs, unlike non-concord adverbs (*e.g.*, temporal adverbs), disallow the in-situ *wh*-phrase, which, as we saw in 2.2.1, is acceptable otherwise?

2.2.3 Puzzle 3: scrambling puzzle

Importantly, however, we can ameliorate the sentence in (13)b, by changing the order of the *wh*-phrase and the concord adverb. This is illustrated in (14).² When the concord

² The acceptability judgement about the sentence in (14)b seems to vary among native speakers. Some say that the sentence in (14)b is just as good as the sentence in (10), while, for others, the sentence in (14)b is marginally acceptable; *n.b.*, as will be discussed in the subsequent sections, in order for the sentence to be accepted, the sentence should be pronounced in a particular prosodic contour. Although detailed examinations on the inter-speaker variation need to be done in future studies, there seems to exist a robust observation that even those who judge the sentence in (14)b to be not as good as the baseline sentence in (10) find that the sentence in (14)b is, at least, better than (14)a. Thus, this paper assumes that the acceptability judgments are ordered *s.t.*, (10) ≥ (14)b > (14)a and puts a question mark for (14)b.

have an interaction with *wh*-elements, it is predicted that the sentences *what could it be?* and *what do you think he could make?* would also be ruled out, contrary to the fact. Second, and more importantly, the acceptability of (14)b cannot be accounted for. In this sentence, *nani-o* is overtly scrambled over *mosi*. The above theory predicts that the sentence should be unacceptable for the same reason. Nevertheless, this sentence is accepted unlike the sentence in (14)a.

Failure of such an intervention-based syntactic analysis, thus, makes us pursue a different direction. In the next section, I present a phonology-oriented view that regards the unacceptability of the above sentences as a violation of prosodic requirement.

3. Contiguity Theory

3.1 Outline

The framework I adopt in this paper is that of Contiguity Theory (hereafter *CT*), proposed and developed by Richards (2010, 2016, 2018). This theory is based on the standard Minimalist Program (MP, Chomsky 1995, 2000, 2001) except for its central claim that syntax makes more reference to phonology than is generally assumed. Under the traditional MP, phonological operations are assumed to take place at PF and we must wait for all the syntactic operations to finish in order to manipulate phonological substance. In contrast, CT assumes that the narrow syntax begins the construction of a prosodic representation as well as a syntactic representation, and that these two structures are isomorphic to each other. That is, during the course of derivation, if the prosodic tree is somehow modified, the syntactic tree must also be changed to maximize their correspondence and vice versa.

One illustrative example is the *wh*-movement. Consider the derivation of the free relative, *e.g.*, [_{CP} *what your sister bought*]. Step 1 in (16) illustrates the situation wherein probe C is merged. In addition to the syntactic tree in (16)a, the corresponding prosodic tree is also created, as in (16)b; in Richards (2016), the algorithm of Match Theory is taken for granted in the process of creating this prosodic tree, which I also take to be the case throughout this paper (see for example Selkirk 2009, 2011; Elfner 2012; Clemens 2014; Bennett, Elfner and McCloskey 2016).

(16) Step 1

- a. syntactic structure: [_{CP} C [_{TP} your sister [bought what]]]
- b. prosodic structure: (_α C ((your sister) (bought what)))

Finally, as clearly indicated by the two-row representations from (16) to (23), the prosodic tree is created in parallel with the syntactic derivation, in sharp contrast with the framework that assumes the post-syntactic phonology.

3.2 Notation

As seen above, the active edge in the prosodic tree plays an important role in CT. In the tree representation, I would use a vertical line to indicate an active edge, in place of opening/closing parentheses which have been used in previous studies; this is just for the sake of ease in interpretation. Via Merge, two syntactic objects α and β are combined to form a new object γ (= (25)a). If the given language has a left-edge active property, the prosodic tree corresponding to this syntactic object is given in (25)b; if it is a right-edge active language, the syntactic tree in (25)a is mapped to (25)c.

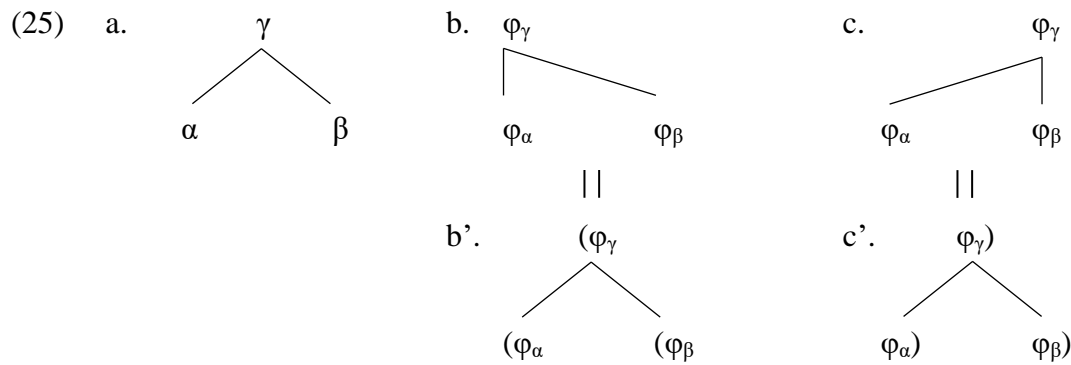

4. Analysis

4.1 Adjunct puzzle

So, how do we explain the three puzzles? Consider the adjunct puzzle first, *i.e.*, the sentence in (10) (= (12)a), repeated here as (26) below.

(26) Japanese

[_{CP} [_{CP} *Nani-o ire-te-tara*] *oisik-u nat-ta ka-naa*]?
what-ACC put-PRF-if delicious-ADV become-PST **Q-SFP**

‘What_i would (it) have become delicious [_{CP} if I had put ~~what_i~~ in it]? (lit.)’

The prosodic tree of this sentence is schematically drawn in (27). The contiguity-prominent element, *i.e.*, the circled goal element (*nani-o* ‘what’), is at the left edge of the node φ_2 , which also dominates the corresponding probe C-head, *i.e.*, the boxed element (*-ka* ‘Q’), satisfying the contiguity requirement. Hence, it is licit.

(27)

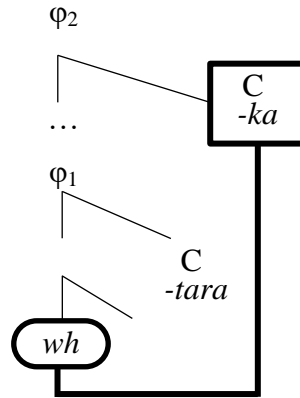

Even when we have an extra element at the beginning of the adjunct clause as in (28), the grouping operation enables us to establish a contiguity relation between the *wh*-element and the corresponding probe (*-ka*). The prosodic tree in (29)a is transformed to (29)b, in which the circled element is at the left edge of φ_2 .

(28) [_{CP} [_{CP} *Anotoki nani-o ire-te-tara*] *oisik-u nat-ta ka-naa*]?
 that time **what-ACC** put-PRF-if delicious-ADV become-PST **Q-SFP**
 ‘What_i would (it) have become more delicious [_{CP} if I had put *t_i* in it then]? (lit.)’

(29) Grouping

a.

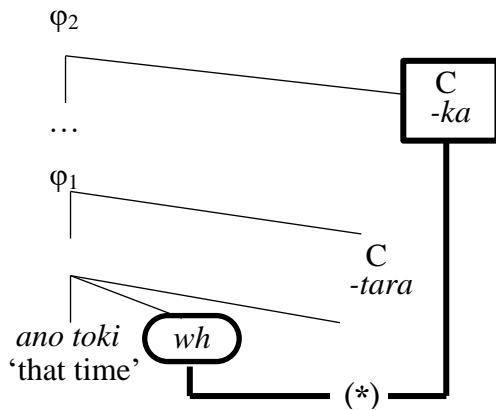

b.

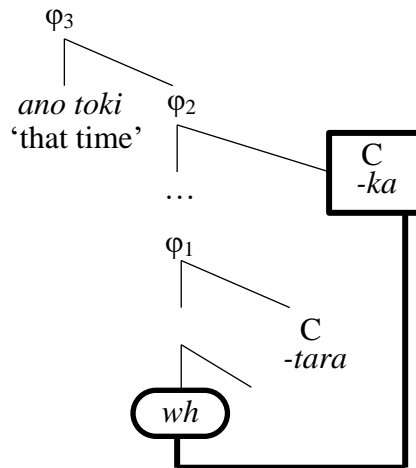

4.2 Adverb puzzle

However, we cannot explain the unacceptability of the sentence in (13)b (repeated here as (30)) by only relying on the contiguity requirement. The concord adverb *mosi* is no less an adverbial phrase than the temporal adverb *anotoki* ‘at that time.’ The prosodic tree should look the same as (29)a, which we predict we can ameliorate by Grouping. The contiguity requirement is predicted to be fulfilled. So, the sentence in (30) should be as good as (28), contrary to the fact.

- (30) *_{[CP [CP} *Mosi* *nani-o* *ire-te-tara]* *oisik-u* *nat-ta* *ka-naa*]?
 CON.ADV what-ACC put-PRF-if delicious-ADV become-PST Q-SFP
 ‘What_i would (it) have become delicious [_{CP} if I had put ~~what_i~~ in it at that time]? (lit.)’

To explain this, I make two novel claims. First, concord adverbs like *mosi* are also contiguity prominent elements; these establish a probe-goal relation with the corresponding conditional head. One empirical motivation comes from the fact that *mosi* shows a high pitch boosting in pitch contour, just like *wh*-elements (*cf.*, Figure 2 and Figure 3 below). Being a contiguity prominent element, *mosi* needs to respect the contiguity requirement. Second, I assume that there exists another requirement on the prosodic tree that defines well-formed contiguity relations, which I call CRYSTALLIZATION:

- (31) **Crystallization:** In the linear configuration, ...**X**...*Y*...**Z**...,
 a potentially contiguity prominent element *Y* cannot be contiguity prominent, if **X** and **Z**
 have already created a contiguity relation.

For example, consider the tree in (32). Assume we want to make two independent contiguity relations — first, between **X** and **Z** and, then, between *Y* and **W**. In (32), the two chains of contiguity relations seem licit in that the contiguity prominent element appears at the left edge (= they both appear at the bottom of the vertical lines). However, *Y* falls within the contiguity region created by **X** and **Z**. What the requirement in (31) bans is such a configuration wherein a contiguity-prominent element appears inside another contiguity chain. We can metaphorically paraphrase the idea as follows. The contiguity region **X-Z** has ‘crystallized’ so that elements within this domain should lose their prominence. Hence, *Y* cannot form the expected contiguity relation with **W** as long as it stays in this crystallized region.

(32)

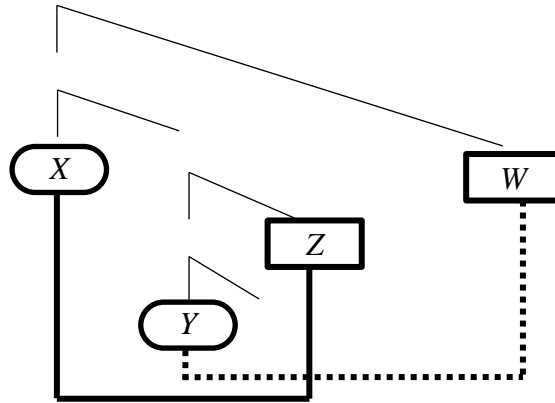

The only difference between (28) and (30) lies in the fact that the sentence in (30) has two independent contiguity relations. First, the contiguity relation between *nani-o* ‘what-ACC’ and *-ka* ‘C’ is checked in both sentences. Second, (30) has a concord adverb. Thus, in addition to the contiguity relation of the *wh*-phrase, this sentence has to form another contiguity relation between *mosi* and *-tara*. The tree in (33)a is the prosodic tree for the adjunct clause. Since *mosi* is on the left edge of ϕ_1 , which dominates its partner *-tara*, the contiguity relation for the concord adverb is satisfied. However, at this moment, the *wh*-element, *nani-o* ‘what-ACC’ is stranded, because the corresponding probe *-ka* has not been merged into the tree. The tree in (33)b illustrates the moment, where the *-ka* is merged into the main clause. Because *mosi* stays in the left-edge of ϕ_2 , we may want *mosi* to make a string vacuous movement via Grouping, so *nani-o* ‘what-ACC’ is ready to be contiguous to its probe. However, with or without Grouping, the linear order of the items are the same and, both in (33)b and (33)c, *nani-o* ‘what-ACC’ is sandwiched by *mosi* and *-tara*. Because of the crystallization, *nani-o* ‘what-ACC’ loses its salience, so we fail to establish the expected relation between the two elements. Thus, the word order in (30) never lets us check the contiguity requirement.

(33) a.

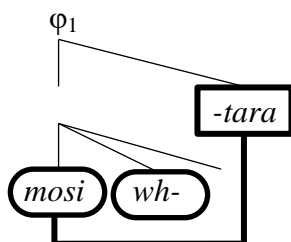

b.

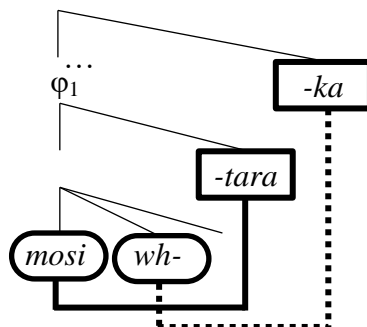

c.

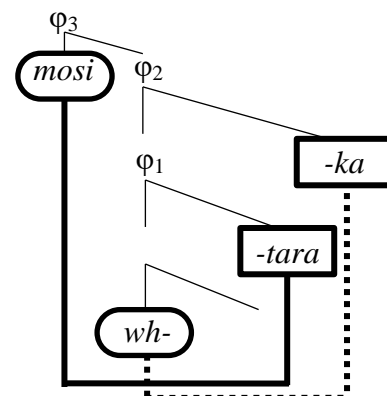

4.3 Scrambling puzzle

However, just as English *wh*-movement serves as a remedy for the violation of the contiguity requirement, we can circumvent the ill-formed configuration in (33)b, by letting the *wh*-element make an altruistic movement; *n.b.*, ‘altruistic’ here means that the movement is not triggered by an intrinsic feature of the *wh*-element but rather it is done in order to contribute to create an acceptable prosodic geometry. The derivation is shown in (34). The course of the derivation is exactly the same up to (33)b but, instead of *mosi*, we move the *wh*-element. In (34)c, the contiguity relation between the *wh*-element and the matrix C is satisfied, because *nani-o* ‘what-ACC’ has now escaped from the crystallized region and has recovered its prominence. The contiguity relation between the *nani-o* and *-ka* has now been successfully established, yielding a well-formed sentence. Even though *mosi* falls inside the crystallized region, this does not cause any problem, because the contiguity requirement between *mosi* and *-tara* has already been checked in (34)a.

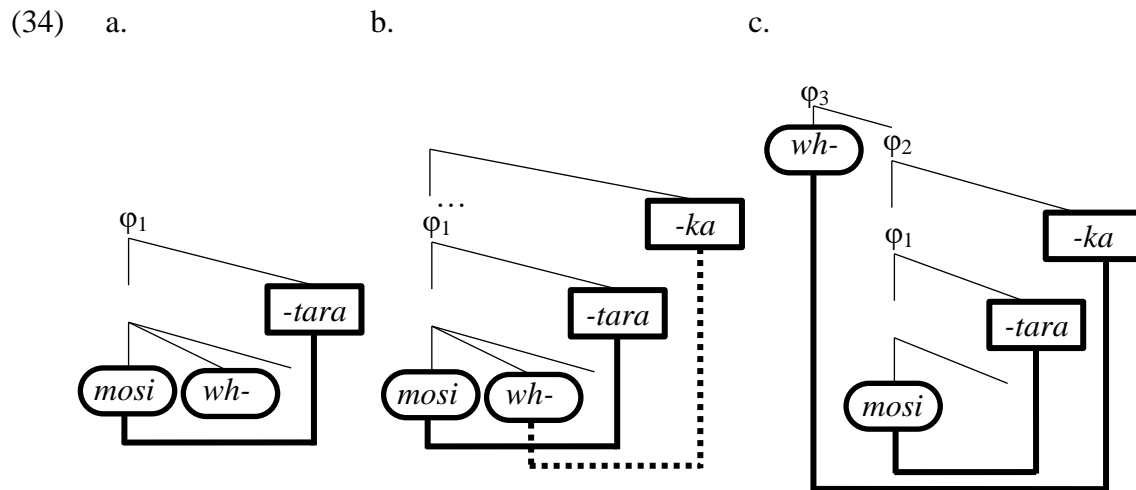

To recap, this section has provided answers to the three puzzles within the framework of CT, without assuming any diacritic features. Acceptable and unacceptable sentences discussed in this paper are all explained on phonological grounds; the contiguity requirement, the *wh*-movement in the prosodic tree, Grouping and Crystallization. First, the adjunct puzzle comes from the fact that English cannot improve the prosodic tree via Grouping, unlike Japanese. Second, the adverb puzzle is attributed to the fact that Crystallization nullifies Grouping. Third, the scrambling puzzle is also understood as a remedy to avoid an ill-formed prosodic configuration, just as English *wh*-movement is triggered on phonological grounds. In all these cases, movements are motivated by the necessity of creating a prosodically well-formed representation.

5. Interpretation

One might wonder whether Crystallization is just a stipulation designed only to explain the three puzzles above. But indeed, we can motivate and give a very natural interpretation to this prosodic requirement. To see this, observe the pitch-contours in Figures 1 through 3, which illustrate the prosodic profiles of (10), (13)b and (14)b.

The sentence in (10) contains only one contiguity prominent element, *nani-o* ‘what-ACC,’ which seeks for its corresponding probe element *-ka* ‘C.’ This correspondence is reflected in the pitch-boosting and its post-focal reduction region (Maekawa 1991; Tomioka 1997; Deguchi and Kitagawa 2002; Ishihara 2002, 2003; Kitagawa 2005, 2017; see also Kubo 2001 for Fukuoka Japanese). The contiguity prominent element triggers a high-pitch boosting and the post-focal reduction continues until it hits its probe *-ka(-naa)*. The double headed arrows illustrate the relevant correspondence.

The sentence in (13)b has two contiguity prominent elements and, as is clearly seen in Figure 2, each element is associated with pitch-boosting. However the two contiguity relations, *i.e.*, the two arrows, are ‘entangled,’ so to speak. The sentence in (14)b also has two chains of probe-goal relations but one is nested inside the other.

Crystallization does not ban overlapping post-focal reductions. Rather, it rules out non-nested relations. In the entangled situation, the post-focal reduction of *mosi* is interrupted by the boosting of *nani-o*. On the other hand, in the nested configuration, the two relations can coexist. By giving stronger pitch-boosting to *nani-o* and by assigning weaker pitch-boosting to *mosi*, we can easily detect which boost corresponds to which head. By observing crystallization, we end up having acoustically well-designed nested post-focal reductions.

6. Conclusion

Why does human language exhibit the displacement property? The Strongest Minimalist Thesis (STM) predicts that language is an optimal solution and importance of interface conditions has been acknowledged since the inception of the Minimalist Program (Chomsky 1995, 2000, 2001). The idea that the EPP-feature must be eliminated at the interfaces is an instantiation of the spirit of this program; since it is not interpretable at the interfaces, this virus has to be taken away. Movements are understood as a consequence of the interface conditions. However, as a drawback, we have used a mysterious diacritic feature whose existence is just a restatement of the problem.

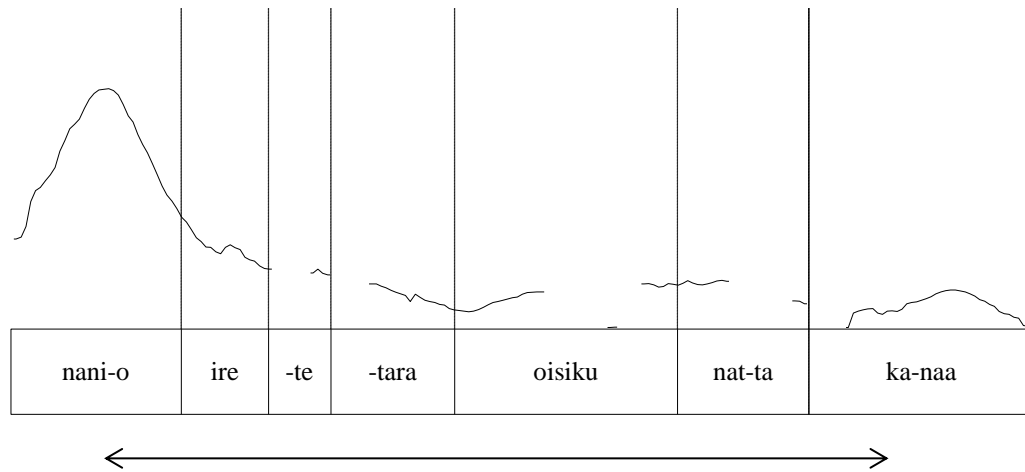

Figure 1 Pitch contour for the sentence in (10) (= (12)a and (26)) (well-formed pitch contour).

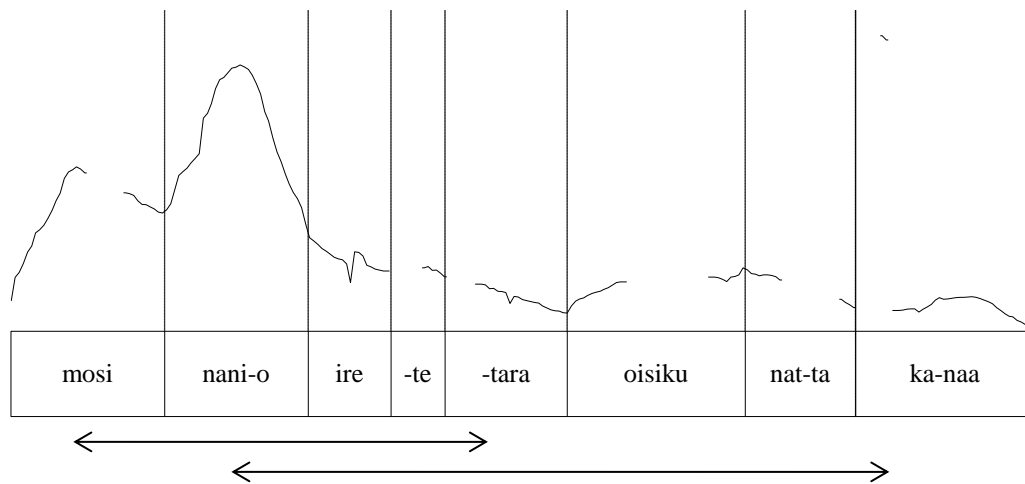

Figure 2 Pitch contour for the sentence in (13)b (= (30)) (ill-formed pitch contour).

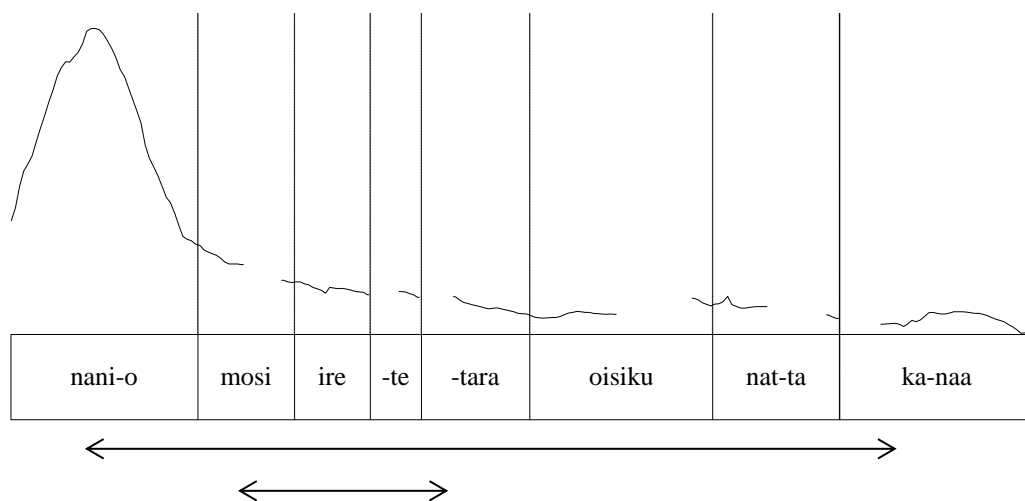

Figure 3 Pitch contour for the sentence in (14)b (well-formed pitch contour).

If we pursue an EPP-free syntax, interface conditions are good candidates that are likely to be responsible for the motivation for movements. Contiguity Theory pushes this idea, arguing that phonological conditions play more roles in syntax than we traditionally assume and that apparent syntactic differences between languages are always the consequence of more fundamental phonological and morphological parameters. Furthermore, CT argues that movements are triggered by phonological requirements of the prosodic tree, which is built in parallel with the syntactic tree. The architecture of this theory enables us to dispense with a strange theoretical construct while maintaining the important spirit of phonology/semantics-oriented syntax.

By discussing three puzzles regarding Japanese conditional clauses and their interaction with *wh*-elements and concord adverbs, this paper has investigated this theoretical possibility and has proposed that a requirement on the prosodic tree — the contiguity requirement (Richards 2010, 2016, 2018; Branan 2018) — should obey another condition, which I call CRYSTALLIZATION. This is a meta-criterion, in the sense that it is a requirement for the contiguity requirement, which distinguishes between well-formed configurations (in which the contiguity requirement can be checked) and ill-formed configurations (in which it misfires).

Emphasis should be placed on the fact that the existence of such a condition is justified on an acoustic ground, that is, as a consequence of an attempt to create a well-formed pitch-boosting distribution. Crystallization guarantees that the post-focal reductions are nested. In the non-nested configuration, it is difficult for us to acoustically relate the contiguity prominent elements to their probes. This constraint is, thus, understood as a natural consequence of a well-designed acoustic property of natural languages. In other words, constraints on movement are argued to be empirically detectable and justifiable by easily accessible E-language properties, exhibiting a sharp contrast with attempts that blindly exploit features which cannot be observed other than their ability to trigger overt movement.

References

- Agbayani, Brian, Chris Golston and Toru Ishii (2015). Syntactic and prosodic scrambling in Japanese. *Natural Language and Linguistic Theory* 33, 47-77.
- Bennett, Ryan, Emily Elfner and James McCloskey (2016) Lightest to the right: an apparently anomalous displacement in Irish. *Linguistic Inquiry* 47(2), 169-234.
- Branan, Kenyon Garrett (2018). *Relationship preservation*. Doctoral dissertation. MIT.
- Chomsky, Noam (1995) *The minimalist program*. Cambridge, MA: MIT Press.

- Chomsky, Noam (2000) Minimalist inquiries: the framework. In Roger Martin, David Michaels and Juan Uriagereka (eds.), *Step by step: essays on Minimalist syntax in honor of Howard Lasnik*, 89-155. Cambridge, MA: MIT Press.
- Chomsky, Noam (2001) Derivation by phase. In Michael Kenstowicz (ed.), *Ken Hale: a life in language*, 1-52. Cambridge, MA: MIT Press.
- Clemens, Lauren Eby (2014) *Prosodic noun incorporation and verb-initial syntax*. Doctoral dissertation. Harvard University.
- Deguchi, Masanori and Yoshihisa Kitagawa (2002) Prosody and *wh*-questions. *Proceedings of the thirty-second annual meeting of the North-Eastern Linguistic Society*, 73-92.
- Elfner, Emily (2012) *Syntax-prosody interaction in Irish*. Doctoral dissertation. University of Massachusetts, Amherst.
- Harada, Shi-Ichi (1977) Nihongo ni henkei wa hitsuyô da [Transformations are needed in Japanese]. *Gengo* 6. 88-103.
- Hoji, Hajime (1985) *Logical form constraints and configurational structures in Japanese*. Doctoral dissertation. University of Washington.
- Inoue, Kazuko (1976) *Heikei bunpô to nihongo [Transformational grammar and Japanese]*. Tokyo: Taishukan.
- Ishihara, Shinichiro (2002) Invisible but audible *wh*-scope marking: *wh*-constructions and deaccenting in Japanese. *Proceedings of the twenty-first West Coast Conference on Formal Linguistics*, 180-193.
- Ishihara, Shinichiro (2003) *Intonation and interface conditions*. Doctoral dissertation. MIT.
- Kitagawa, Yoshihisa (2005) Prosody, syntax and pragmatics of *wh*-questions in Japanese. *English Linguistics* 22, 302-346.
- Kitagawa, Yoshihisa (2017) Interfacing syntax with sounds and meanings. In Masayoshi Shibatani and Taro Kageyama (eds.), *Handbooks of Japanese language and linguistics* 4, 497-551.
- Kubo, Tomoyuki (2001) Syntax-phonology interface in the Fukuoka dialect. *Journal of the Phonetic Society of Japan* 5, 27-32.
- Kudo, Hiroshi (1982) Zyohô hukushi no imi to kinô [Meaning and function of the modal adverb] *Kokuritsu kokugo kenkyûzyo hôkoku: Kenkyû hôkokushû* 3 [Research report 3] 71, 45-92.
- Kudo, Hiroshi (2000) Hukushi to bun no chinzyutsu teki na taipu [Classes of concords between adverbs and sentences]. In *Modaritî [Modality]*, 161-234.
- Kuroda, S.-Y. (1965) *Generative grammatical studies in the Japanese language*. Cambridge, MA: MIT dissertation.

- Kuroda, S.-Y. (1988) Whether we agree or not: a comparative syntax of English and Japanese. *Linguisticae Investigationes* 12. 1-47.
- Maekawa, Kikuo (1991) Perception of intonation characteristics of WH and non-WH questions in Tokyo Japanese. *Proceedings of the XXIIInd International Congress of Phonetic Science* 4. 202-205.
- Mihara, Kenichi (2012) Katsuyô no keitairon, tôgoron, oninron, tsûji. In Kenichi Mihara and Yoshio Nitta (eds.), *Katsuyôron no zensen [Frontiers in inflectional morphology]*, 115-151. Tokyo: Kuroshio Publishers.
- Miyagawa, Shigeru (2003) A-movement scrambling and options without optionality. In Simin Karimi (ed.), *Word order and scrambling*, 177-200. Oxford: Blackwell.
- Miyagawa, Shigeru (2005) EPP and semantically vacuous movement. In Joachim Sabel and Mamoru Saito (eds.), *The free word order phenomenon: Its syntactic sources and diversity*, 181-220. Berlin: Mouton de Gruyter.
- Miyagawa, Shigeru (2011) Optionality. In Cedric Boeckx (ed.), *The Oxford handbook of linguistic minimalism*, 354-376. Oxford: Oxford University Press.
- Miyagawa, Shigeru (2012) *Case, argument structure, and word order*. New York: Routledge.
- Morimoto Junko (1994) *Hanashite no syukan o arawasu hukushi nitsuite [On the adverbs expressing speaker's subjectivity]*. Tokyo: Kuroshio Publishers.
- Morimoto Junko (2011) Nichieigo no syukansei o arawasu hukushi nitsuite [On the Japanese and English adverbs expressing Subjectivity]. In Osamu, Sawada (ed.), *Hitsuji imiron kôza 5: syukansei to syutaisei [Hitsuji's lectures on semantics 5: subjectivity and subjectivity]*. Tokyo: Hitsuji Shobo.
- Muraki, Masatake (1974) *Presupposition and thematization*. Tokyo: Kaitakusha.
- Richards, Norvin (2010) *Uttering trees*. Cambridge, MA: MIT Press.
- Richards, Norvin (2016) *Contiguity theory*. Cambridge, MA: MIT Press.
- Richards, Norvin (2018) *Contiguity-prominence: a prosodic parameter with syntactic consequences*. Oral presentation presented at the forty-ninth annual meeting of the North-Eastern Linguistic Society.
- Saito, Mamoru (1985) *Some asymmetries in Japanese and their theoretical implications*. Doctoral dissertation. Cambridge, MA: MIT.
- Saito, Mamoru (1989) Scrambling as semantically vacuous A'-movement. In Mark R. Baltin and Anthony S. Kroch (eds.), *Alternative conceptions of phrase structure*, 182-200. Chicago: University of Chicago Press.
- Saito, Mamoru (1992) Long distance scrambling in Japanese. *Journal of East Asian Linguistics* 1. 69-118.

- Saito, Mamoru (2003) A Derivational approach to the interpretation of scrambling chains. *Lingua* 113. 481-518.
- Saito, Mamoru (2004) Japanese scrambling in a comparative perspective. In David Adger, Cécile de Cat and George Tsoulas (eds.), *Peripheries: Syntactic edges and their effects*, 143-163. Dordrecht: Kluwer.
- Saito, Mamoru (2005) Further notes on the interpretation of scrambling chains. In David Sabel and Mamoru Saito (eds.), *The free word order phenomenon: Its syntactic sources and diversity*, 335-376. Berlin: Mouton de Gruyter.
- Saito, Mamoru (2010) Semantic and discourse interpretation of the Japanese left periphery. In Nomi Erteschik-Shir and Lisa Rochman (eds.), *The sound patterns of syntax*, 140-173. Oxford: Oxford University Press.
- Sawada, Osamu (1993) *Shiten to syukansei: nichieigo zydôshi no bunseki* [Viewpoint and subjectivity: analysis on the Japanese and English adverbs]. Tokyo: Hitsuji Shobo.
- Selkirk, Elisabeth (2009) On clause and intonational phrase in Japanese: the syntactic grounding of prosodic constituent structure. *Gengo Kenkyu* 136. 35-73.
- Selkirk, Elisabeth (2011) The syntax-phonology interface. In John Goldsmith, Jason Riggle and Alan Yu (eds.), *The handbook of phonological theory*, 435-484. Oxford: Wiley-Blackwell.
- Sugimura, Yasushi (2012) *Hukushi to modaritii*. [Adverbs and modality]. Tokyo: Kuroshio Publishers.
- Tokieda, Motoki (1950) *Nihongo bunpô kôgohen* [Japanese grammar (colloquial style)] Tokyo: Iwanami Shoten.
- Tomioka, Satoshi (1997) *Wh-in-situ, subjacency, and LF syntax*. Paper presented at LSA Summer Institute, Cornell University.
- Watanabe, Minoru (1971) *Kokugo kôbunron*. Tokyo: Hanawa Shobo.
- Yamada, Akitaka (2014) *Zyôkensetsu no tógobunseki: nihongo no zirei ni motoduku ketsurakusetsu to idôsetsu no hikaku* [Syntactic analysis on conditional clauses: comparison between truncation approach and movement approach on the basis of Japanese conditionals]. *Gengojuhokagaku* 12, 37-54.
- Yamada, Yoshio (1936) *Nishongo bunpôgaku gairon* [Japanese grammar overview]. Tokyo/Osaka: Hôbunkan.
- Yoshimura, Noriko (2017) Scrambling. In Masayoshi Shibatani and Taro Kageyama (eds.), *Handbooks of Japanese language and linguistics* 4, 807-843.